

# A Nephelometric Turbidity System for Monitoring Residential Drinking Water Quality

Theofanis P. Lambrou<sup>1</sup>, Christos C. Anastasiou<sup>2</sup>, and Christos G. Panayiotou<sup>1</sup>

<sup>1</sup> Dept. of Electrical and Computer Engineering,  
University of Cyprus, Nicosia, Cyprus.

{faniseng, christosp}@ucy.ac.cy

WWW home page: <http://www2.ucy.ac.cy/~faniseng/>

<sup>2</sup> Dept. of Civil and Environmental Engineering,  
Frederick University Cyprus, Nicosia, Cyprus.

{c.anastasiou}@frederick.ac.cy

**Abstract.** In this paper the design and development of a turbidity system for monitoring drinking water quality in households is presented. Its operation is based on the principle that the intensity of the light scattered by the suspended matter is proportional to its concentration. Unlike the commercially available turbidity meters, which are relatively expensive and bulky, the proposed device is small-sized, low power, lightweight, easy to use and inexpensive. Laboratory tests of the device have yielded satisfactory repeatability and precision. This sensor can be used as a part of a low cost sensor network consisting of different types of sensors (pH, temperature, chloride, etc) to provide water quality information to consumers. Fusing on-line multi sensor measurements, the system can provide useful information regarding hazardous agents and waterborne pathogens contaminants of household drinking water raising awareness and encourage better water-handling.

**Key words:** Turbidity measurement, turbidity sensor, nephelometry, water quality, light scattering sensor.

## 1 Introduction and definition

Turbidity is the measurement of scattered light that results from the interaction of incident light with suspended and undissolved material in a water sample and it is an important water quality indicator. Turbidity is defined by the International Standards Organization (ISO) as the reduction of transparency of a liquid caused by the presence of undissolved matter. Turbidity can be interpreted as a measure of the relative clarity of water and often indicates the presence of dispersed, suspended solids; particles not in true solution such as silt, clay, algae and other microorganisms; organic matter and other minute particles. Solids in drinking water can support growth of harmful microorganisms and reduce the effectiveness of disinfection processes (i.e. chlorination, UV irradiation) resulting in increased health risks. In almost all water supplies, high levels of suspended

matter are unacceptable for aesthetic reasons and can interfere with chemical and biological tests.

Further, there is a need to find a surrogate for continuous monitoring of water-quality conditions, for both *potable water systems*, as well as for *wastewater facilities* and *natural water systems*, because traditional sampling techniques often are labor intensive and costly; data collection can be potentially unsafe; and, most importantly, there typically can be long time delays between sample collection, chemical analysis, and the posting of results.

Excessive turbidity, or cloudiness, in potable water is aesthetically unappealing, and may also represent a health concern. Turbidity can provide food and shelter for pathogens. If not removed, turbidity can promote regrowth of pathogens in water distribution systems, leading to waterborne disease outbreaks, which have caused significant cases of gastroenteritis throughout the world. Suspended solids (the particles of turbidity) provide “shelter” for microbes by reducing their exposure to disinfectants. Further, waters with high turbidity from organic sources may give rise to a substantial chlorine demand. This could result in reductions in the free chlorine residual in distribution systems as protection against possible recontamination. Drinking water can serve as a transmission vehicle for a variety of hazardous agents (*E. coli*, Legionella, arsenic, etc). Contaminants in drinking water can produce adverse effects in humans due to multiple routes (ingestion, inhalation and dermal) of exposure. In the EU, the quality of water intended for human consumption is governed by the Drinking Water Directive (DWD), Council Directive 98/83/EC. According to DWD [5] a set of microbiological and chemical parameters must be monitored and tested regularly and their values cannot exceed a predetermined threshold. Such parameters include Turbidity, Conductivity, *E. Coli*, pH, odour, taste etc. Moreover WHO [6] recommends the surveillance of household water storage systems as this water is more vulnerable to contamination. Regarding WHO [6] and EU DWD [5] drinking water turbidity value must not exceeding 1,0 NTU (nephelometric turbidity units) in the water ex treatment works. The appearance of water with a turbidity of less than 5 NTU is usually acceptable to consumers.

In many countries (e.g Mediterranean region), given the fact that most water quality regulations pertaining to drinking water are applied before or at the point where water enters the distribution system, often makes it impossible for authorities and consumers to know the quality of potable water reaching their homes. Further, water cuts (due to decreasing water sources) put extra strain on the integrity of the distribution network, thus making water more susceptible to contamination before it reaches consumers. Moreover, many residences in water stress countries are making use of individual water reservoir tanks that are meant to store water for during the times that direct water supply is not feasible; standing conditions and remaining substances makes tank water vulnerable to contamination. Some epidemiological and outbreak investigations conducted, suggest that a substantial proportion of waterborne disease outbreaks is attributable to problems within distribution systems [4]. Studies of water distribution systems have shown related findings with respect to turbidity and

microorganisms [2]. Haas et al [1] noted that increased values of pH, temperature and turbidity were associated with increased concentrations of microorganisms.

Under the circumstances mentioned above, it would be extremely useful, if a real-time turbidity monitoring system could be installed to act as a type of “early warning system” for possible potable water quality deterioration at homes. For such a system to be implementable though, turbidity systems that are cheap, easy to install and use, and could have capabilities of sending information, wirelessly, to a central data logging and processing facility would be essential. The main contribution of this paper is the development of such a system. Further to the aforementioned possible home use, currently, two separate research projects are under way, both of which are based on the above rationale. The first of these projects will seek to identify the level to which water rationing measures enforced in Cyprus influence the quality of potable water reaching consumers, while the second of the two projects seeks to identify the effect that storing water in roof-mounted reservoir tanks influences water quality in homes.

The remaining of the paper is organized as follows: Section 2 presents the basic turbidity measuring techniques. Section 3 describes the design and development of the the proposed turbidity system. Section 4 describes the sensor calibration method and testing results. In Section 5 describes some interferences in turbidity measurement in drinking water applications. The paper concludes with Section 6.

## 2 Turbidity Measuring Techniques

Turbidity is measured using the techniques of turbidimetry or nephelometry and is expressed in arbitrary units (Nephelometric Turbidity Unit, NTU). The direct relationship between turbidity data and suspended solids concentration depends on many factors, including particle size distribution, particle shape and surface condition, refractive index of the scattering particles and wavelength of the light.

There are three basic designs of turbidity meters [7],[8]:

- the *nephelometer*, which measures directly the intensity of light scattered by the sample. The light intensity is directly proportional to the amount of matter suspended in the light path. The sensor is mounted at an angle (usually  $90^\circ$ ) to the traversing beam to record scattered light. Nephelometers usually provide greater precision and sensitivity than turbidimeters and are normally used for samples of low turbidity containing small particles.
- the *turbidimeter*, sometimes called absorption meter, which measures the intensity of the beam after it has passed through the sample. Suspended matter in the light path causes scattering and absorption of some light energy. The transmitted light is measured, in relation to initial beam intensity. Turbidimeters are more appropriate for relatively turbid samples in which the scattering particles are large in relation to the light wavelength used.
- the *ratio turbidimeter*, which measures both transmitted and scattered light intensities. For this purpose, transmitted light and  $90^\circ$ -scattered light are mea-

sured simultaneously with two different light sensors, which produce two voltages,  $V_0$  and  $V_{90}$ , respectively. Changes in the light absorption of the process medium, e.g. because of coloring, have the same influence on both light sensors. Thus, the signal ratio,  $V_{out} = \frac{V_{90}}{c_1 \cdot V_0 + c_2 \cdot V_{90}}$  remains unchanged ( $c_1$ ,  $c_2$  are calibration coefficients). This feature has a number of advantages, including the elimination of the effect of coloring on readings and the increase of the long-term stability of the instrument (due to reducing drift of light source intensity). This design appears to be more appropriate for liquids either strongly colored or of variable color concentration, and for samples of high turbidity.

Continuous turbidity monitoring has become increasingly popular, mainly because the alternative practice of sampling and sedimentation analysis or filtration-and-weighing procedures are time-consuming and error-prone. Turbidity sensors probes may also be the only viable means of assessing suspended sediment changes in circumstances where conditions are harsh and access is limited. Generally, turbidity values can serve as a simple and convenient measure of the concentration of suspended solids in water-supply installations. The relatively high price of commercially available turbidity meters spurred intensive research on designing an inexpensive turbidity sensor, which would be reliable, with high frequency response and good spatial resolution, but at the same time easy to fabricate, portable and robust, thus suitable for field measurements.

The purpose of this project is to design and construct a portable, inexpensive and sensitive nephelometer for potable water quality monitoring in households.

### 3 Design and Development

In commercially available instruments, both the light source and the photodetector are usually located inside the sensor housing. In order to reduce the probe size and at the same time to minimize interference with the water, a first attempt was made to place the electronic parts away from the probe using optical fibers. However, because the intensity of the light reaching the photosensor is generally low, as the nephelometer is intended for potable water measurements, even a small attenuation of the transmitted light would greatly affect the sensitivity of the measurements. Therefore, in order to improve the performance of the system, the light sensor was embodied in the probe.

The measuring system under discussion is comprised of the following subsystems as shown in figure 1: An optical sensor (photodiode) and the signal conditioning circuit. A light source (red laser diode) and the laser driver circuit located in the device housing. The laser diode emits light, that is transmitted through an optical gap to the water sample. A PIC (Peripheral Interface Controller) microcontroller with a built in 10-bit Analog-to-Digital converter, a wireless zigbee transceiver for transferring turbidity measurements to measurement server (or a remote LCD display) and a local LCD module to display the turbidity measurement after digital processing. The photodiode is mounted at a  $90^\circ$  angle with respect to the light path. Turbidity is measured using an 670 nm

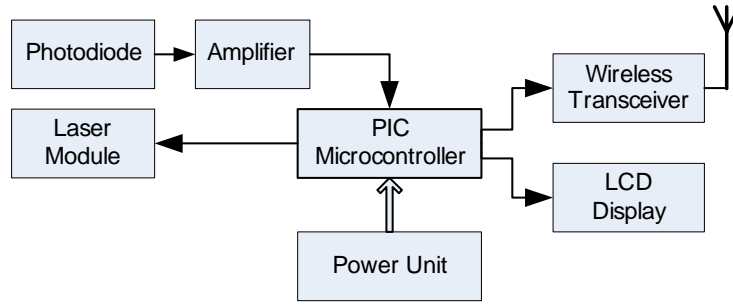

Fig. 1. Turbidity System Architecture

1mW visible red laser diode and detector in a scattered mode. A cross-section view of the sensor is shown in figure 2(a). The diode laser source, which has of high directionality, low power consumption and relatively high light intensity, is used to improve signal to noise ratio (SNR). The photodiode converts the scattered light directly into electrical current. The spectral sensitivity ranging from 500 nm to 800 nm. A high-gain ( $R = 320M\Omega$ ) low-noise CMOS (Complementary metaloxidesemiconductor) transimpedance amplifier converts photocurrent to voltage output (see Figure 2(b)). The conversation is directly proportional to light intensity (irradiance) on the photodiode. Figure 3 shows the PIC microcontroller circuitry schematic and prototype board layout design.

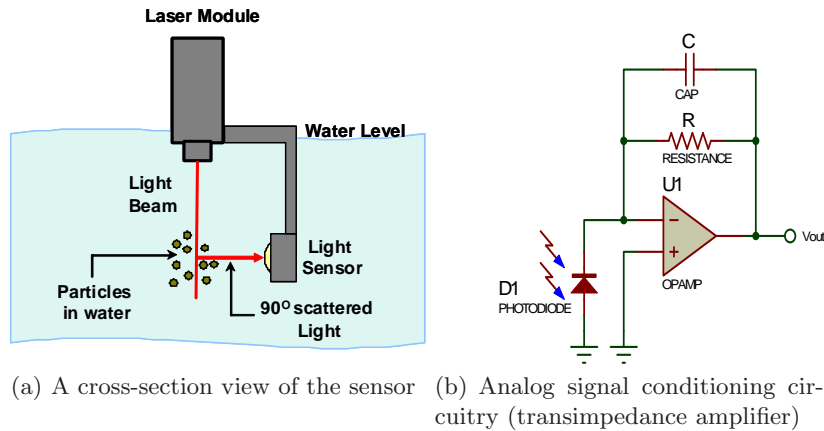
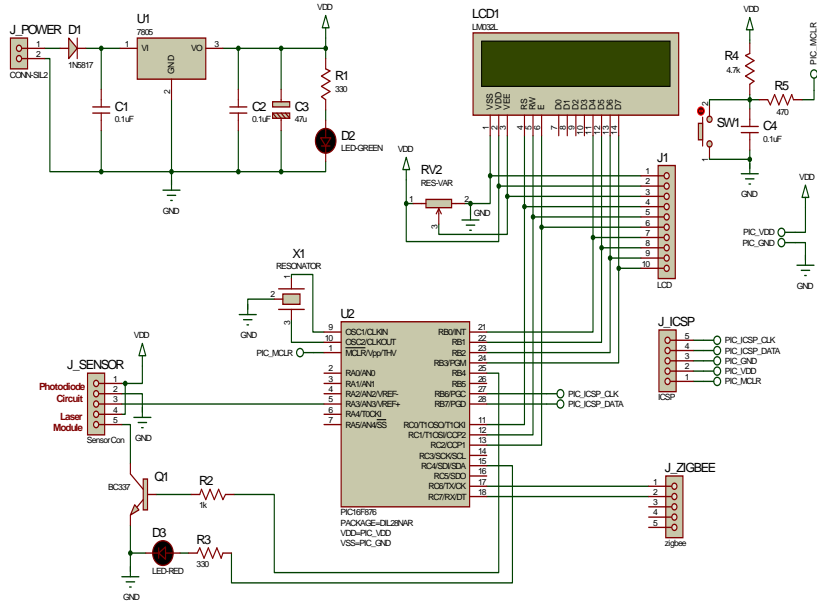
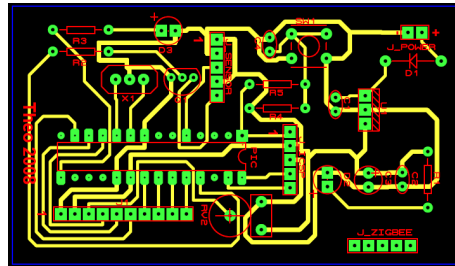

Fig. 2. Water Turbidity Sensor

The probe is a plastic cylinder whose length is 2.5 cm and its diameter 1.5 cm (figure 4(a)). A plastic case houses all other remaining subsystems (microcontroller circuitry, laser source, transimpedance amplifier, LCD display, battery, wireless transceiver, etc) as shown in figure 4(b).



(a) PIC microcontroller circuitry



(b) System board layout

Fig. 3. Turbidity System Schematic

After sampling the sensor signal, the digital sensor value needs further conversion to be transformed to nephelometric turbidity units (NTUs) (see figure 4(c)). Because of the laser light source, the measurements received are very sensitive to small changes in turbidity and thus the output of the sensor is needed to be averaged to develop a smooth turbidity signal. Instantaneous readings may vary considerably as particle density changes or large particles move. We implement a moving average of the past five readings in order to stabilize the output signal. (See figure 5). Finally, the microcontroller performs all the necessary calculations-initializations and displays the resulting signal to the LCD display and also transmits the sense data to a measurement server using the wireless zigbee transceiver.

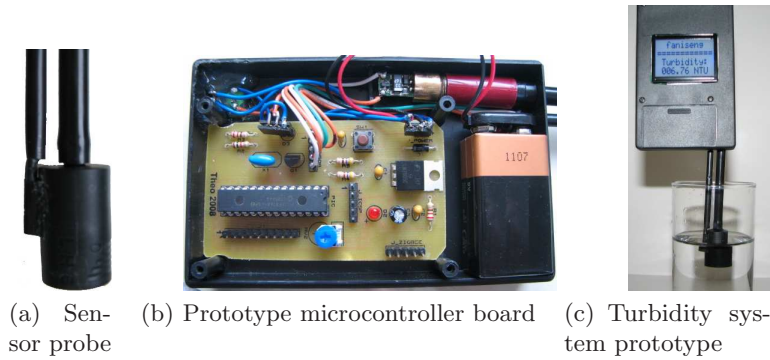

Fig. 4. Turbidity System Photos

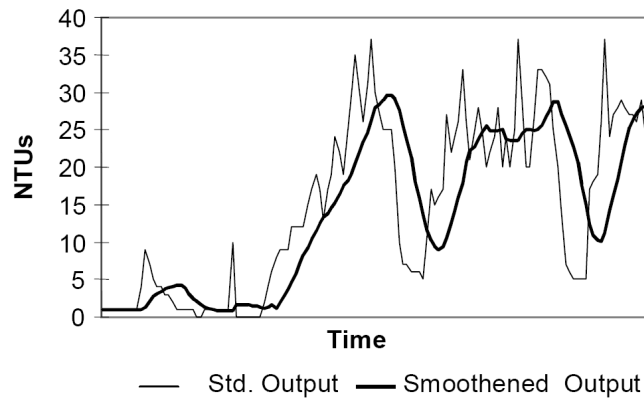

Fig. 5. Moving average of turbidity data

The components for the complete prototype turbidity system cost approximately 30 euros, which is at least an order of magnitude less expensive than commercially available turbidity meters (which their market prices are around 600-1200 euros [11]).

#### 4 Calibration and testing

An indirect method for the sensor calibration was employed, in order to avoid the use of the carcinogen and expensive chemical formazin, a method which is considered as the common practice [7].

The first attempt in developing stable turbidity samples was made by using skim milk (0.1% fat), which forms a homogeneous solution in water. We use a volumetric pipette to mixed skimmed milk with distilled water and create samples of various turbidities, all of which were stable. However, milk is an organic substance which means that it spoils over time. The final attempt was

clearly better; we diluted hydrophilic cutting oil into distilled water using a volumetric pipette. The samples created were stable, homogeneous and non-organic thus they do not change over time.

The calibration procedure is as follows: A number of samples was created by diluted small volumetric values (mL) of hydrophilic cutting oil into 1L of distilled water using a volumetric pipette. Then, the turbidity of each sample is measured both by the new turbidity sensor (see figure 6(a)) and by a commercial turbidimeter (Hach 2100P) used as reference (see figure 6(b)).

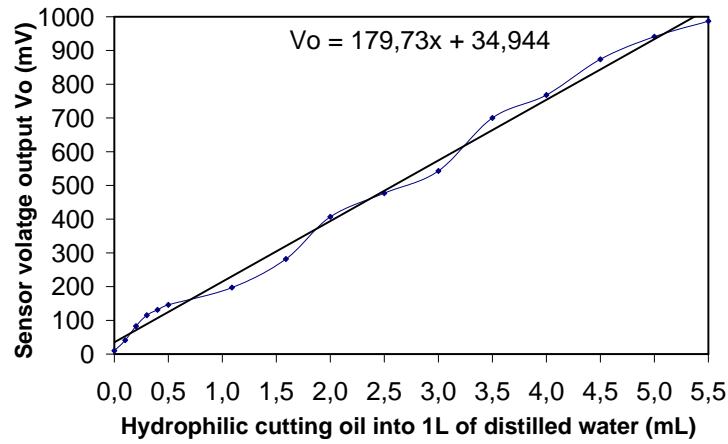

(a) Turbidity sensor voltage output vs hydrophilic cutting oil particles.

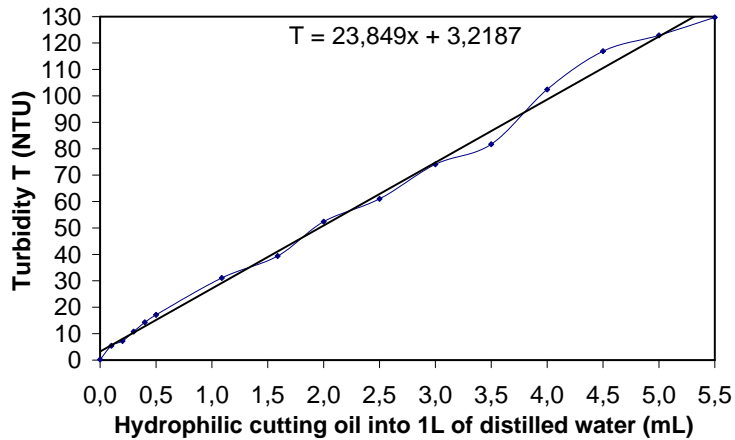

(b) Commercial turbidimeter measurements vs hydrophilic cutting oil particles.

**Fig. 6.** Turbidity System Calibration



Using linear regression the relationship between the  $V_o$  (in  $mV$ ) of the new turbidity sensor and the  $mL$  of the hydrophilic cutting oil into 1L of distilled water (represented by  $x$ ) is given by equation 1 (see figure 6(a)).

$$V_o = 179.73x + 34.944, R^2 = 0,9942 \quad (1)$$

Consequently, the relationship between turbidity  $T$  ( $NTU$ ) measurements of the commercial turbidimeter and the  $mL$  of the hydrophilic cutting oil into 1L of distilled water is given by equation 2 (see figure 6(b)).

$$T = 23.849x + 3.218, R^2 = 0,9958 \quad (2)$$

The combination of equations 1 and 2 gives the relationship between turbidity  $T$  (in  $NTU$ ) and the  $V_o$  (in  $V$ ) of the proposed turbidity sensor as shown by equation 3.

$$T = 132.69V_o - 1.418 \quad (3)$$

Surprisingly, the sensor tends to have almost linear response in the range of  $0 - 100NTU$ . Although negative turbidity values are very unusual to occur the system is programmed to zero such values. The repeatability of the measurements was checked by conducting a series of two sets of experiments and the results were satisfactory. A demonstration of the turbidity system developed is shown in figure 7



Fig. 7. Demonstration of the turbidity system developed

## 5 Interferences in Turbidity Measurement

The measurement of turbidity in drinking water applications is subjected to interferences mainly due to stray light and bubbles in the sample water. Other turbidity interferences are listed in [10]. A positive bias is usually reported from

the previous interferences (slightly higher measurements than the actual turbidity. A usual solution of the stray light interference is the rationing (ratio turbidimeter). This method also improves problems related to color interferences and optical intensity drifts of the light sources. As the bubble interference is concerned the best way to decrease the interferences is to let the sample stand for several minutes to allow bubbles to vacate or perform large integration periods.

## 6 Conclusions and Future Work

### 6.1 Conclusions

The proposed turbidity sensor appears to be suitable for continuous monitoring of potable water quality. The prototype developed is quite appropriate for turbidity measurements in the range of 0-100 NTU with precision of 0.2 NTU. The sensor is battery powered as both the LASER source and the signal conditioning circuitry have very low power requirements moreover the laser diode is switching only during measurements to further reduce power consumption.

The current development can be used as a portable instrument. Modifications in sensor housing can enable in situ measurements of residential premises (i.e housing in a water supply pipe). Unlike some commercial turbidimeters, the proposed instrument is not equipped with a self-cleaning mechanism. In the current development a water shower is adequate to clean the sensor from the impurities deposited during the measurements.

The device is of low cost and easy to develop, the construction materials are easily obtainable and the final cost of the whole device does not exceed 30 euros. This sensor can be used as a part of a low cost sensor network to provide water quality information to consumers.

### 6.2 Future Work

Providing clean drinking water to the population has become an increasing challenge with depletion of water sources and pollution of water bodies. The pollutants in the water can be broadly classified as metals, organic and pathogens. Contaminants in drinking water can produce serious health consequences. There is a need for monitoring the quality of the water at all stages, from the source till the end user. Our goal is to develop low-cost sensors for detecting pollutants in drinking water at residential premises.

Rapid advances in IC technologies and micro-electrical-mechanical systems (MEMS) have enabled the generation of low power and inexpensive sensor networks. Microsystems technology offers new ways of combining sensing, signal processing and actuation on a microscopic scale and allows a wide range of operational environments. The proliferation of wireless sensor networks and the recent efforts for the standardization of sensor communication under the IEEE 802.15.4 and Zigbee standards are beginning to facilitate a rapidly expansion applications. An inexpensive sensor network could be deployed to monitor the

easily-measurable properties of water such as turbidity, temperature, pH, electrical conductance, total dissolved solids, chloride and others which are correlated with water quality.

These properties could be measured with low-cost sensors and provide water quality information. Moreover sensors for arsenic and microbial contamination are currently under research development. It is worth to note that a technique of multi-angle light scattering has been developed for microbial classification. This low-cost sensor network could fuse on-line multi sensor measurements to make a complex decision about the quality of drinking water or even the identification of hazardous agents and waterborne pathogens. Finally the proposed sensor network could raising awareness and encourage better water-handling.

## Appendix: Theory of light scattering

Very simply, the optical property expressed as turbidity is the interaction between light and suspended particles in water. A directed beam of light remains relatively undisturbed when transmitted through absolutely pure water, but even the molecules in a pure fluid will scatter light to a certain degree. Therefore, no solution will have a zero turbidity. In samples containing suspended solids, the manner in which the sample interferes with light transmittance is related to the size, shape and composition of the particles in the solution and to the wavelength (color) of the incident light.

A minute particle interacts with incident light by absorbing the light energy and then, as a point light source itself, reradiating the light energy in all directions. This omnidirectional reradiation constitutes the "scattering" of the incident light. The spatial distribution of scattered light depends on the ratio of particle size to wavelength of incident light [3]. Particles much smaller than the wavelength of incident light exhibit a fairly symmetrical scattering distribution with approximately equal amounts of light scattered both forward and backward (see Figure 8(a)). As particle sizes increase in relation to wavelength, light scattered from different points of the sample particle create interference patterns that are additive in the forward direction. This constructive interference results in forward-scattered light of a higher intensity than light scattered in other directions (see Figure 8(b) and Figure 8(c)). In addition, smaller particles scatter shorter (blue) wavelengths more intensely while having little effect on longer (red) wavelengths. For example blue light tends to be scattered by the oxygen and nitrogen molecules in the atmosphere giving the blue sky we see!. Conversely, larger particles scatter long wavelengths more readily than they scatter short wavelengths of light. Particle shape and refractive index also affect scatter distribution and intensity. Spherical particles exhibit a larger forward-to-back scatter ratio than coiled or rod-shaped particles. The refractive index of a particle is a measure of how it redirects light passing through it from another medium such as the suspending fluid. The particle's refractive index must be different than the refractive index of the sample fluid in order for scattering to

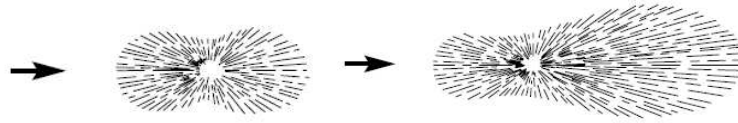

(a) In small particles (smaller than  $1/10$  the wavelength of light) scattering is symmetric (b) In large particles (approximately  $1/4$  the wavelength of light) scattering is concentrated in forward direction

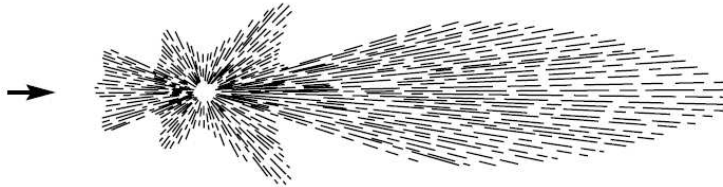

(c) In larger particles (larger than the wavelength of light) scattering is extremely concentrated in forward direction. Also maxima and minima of scattering intensity are developed at wider angles

**Fig. 8.** Angular patterns of scattered intensity from particles of three sizes. (a) small particles, (b) large particles, (c) larger particles.(Source:[3])

occur. As the difference between the refractive indices of suspended particle and suspending fluid increases, scattering become more intense.

The color of suspended solids and sample fluid are significant in scattered-light detection. A colored substance absorbs light energy in certain bands of the visible spectrum, changing the character of both transmitted light and scattered light and preventing a certain portion of the scattered light from reaching the detection system. Light scattering intensifies as particle concentration increases. But as scattered light strikes more and more particles, multiple scattering occurs and absorption of light increases. When particulate concentration exceeds a certain point, detectable levels of both scattered and transmitted light drop rapidly, marking the upper limit of measurable turbidity. Decreasing the path length of light through the sample reduces the number of particles between the light source and the light detector and extends the upper limit of turbidity measurement.

### Acknowledgements

This work is partly supported by the Cyprus Research Promotion Foundation under contracts ENIΣX/0505/30 and ΠΛΗΠΟ/1104/10.

### References

1. C.N.Haas, M.A. Meyer, and M.S. Paller, *Microbial alterations in water distribution systems and their relationship to physical-chemical characteristics*, Journal of American Water Works Association , 1983

2. M.W LeChevallier, and W.D. Norton *Examining Relationships Between Particle Counts and Giardia, Cryptosporidium, and Turbidity*, Journal of American Water Works Association, 1992
3. Brumberger et al. *Light Scattering*, Science and Technology ,1968, page 38.
4. Lee SH, Levy DA, Craun GF, Beach MJ, and Calderon RL. *Surveillance for waterborne disease outbreaks-United States, 1999-2000*, In CDC Surveillance Summaries, November 22, 2002.
5. *European Communities (Drinking Water)(No.2) Regulations 2007*
6. World Health Organization *Guidelines for drinking-water quality, third edition, 2004*
7. D.M Lawler *Turbidimetry and Nephelometry* In Encyclopedia of Analytical Science, 1995, Academic Press Ltd, UK.
8. *Basic turbidimeter design and concepts*. EPA. Turbidity Guidance Manual 1999 <http://www.epa.gov/safewater/mdbp/pdf/turbidity/chap11.pdf>
9. HACH Company. *Portable Turbidimeter Model 2100P, Instrument and Procedure Manual*.
10. M. Sadar *Making Sense of Turbidity Measurements - Advantages in Establishing Traceability Between Measurements and Technology*. In 2004 National Monitoring Conference, Chattanooga, TN, USA.
11. <http://www.google.com/products?q=portable+turbidity+meters>.